

Picture 1

## FITTING INSTRUCTIONS

### SIRIUS CE PRIMARY BELT CLEANER 9930

Tools: measuring tape, weld, cutting tool, wrenches (for M13 and M17) and a drilling machine.

Material: 2 pieces of sheet metal/ flat iron for welding brackets, a 11mm and a 7mm drill.

Sirius CE pre-scraper 9930 is a belt cleaner made from polyurethane segments with an integrated carbide edge, fitted in a removable cassette. Sirius CE has a sturdy design for maximal function and durability in heavy applications with high demands on the cleanliness. Each segment is easy to remove for exchange or cleaning purpose. The segments snap into the aluminium profile easily or can be threaded into the profile sideways.

### CONDITIONS FOR OPTIMUM OPERATION OF SIRIUS

In order to achieve the best cleaning results of the conveyor belt, the following conditions must be met:

- The belt cleaner shall **not** be fitted to chevron belts or belts with mechanical joints.
- The conveyor belt must be free of damage. The belt may otherwise get caught on the scraper segments (1), resulting in a damage on either belt or belt cleaner.
- Max. belt speed: 2.3 m/s
- Max. temperature: + 50°C in wet environments (ambient temperature + frictional heat)
- Max. temperature: + 85°C in dry environments (ambient temperature + frictional heat)

#### CAUTION!

Always turn off the conveyor belt before maintaining, adjusting or installing the belt cleaner. Make sure that the belt cannot start while this work is in progress.

### WARRANTY

The product is covered under 24 months warranty from time of purchase. For questions or claims, please contact our customer service. Damage to the belt cleaner caused by incorrect handling or incorrect installation will not be considered subject to guarantee. Vendig will not be considered responsible for consequences or damage on other equipment or for injury due to incorrect handling or incorrect assembly. Warranty of Vendig's products is limited to manufacturing defects.

## ASSEMBLING

Turn off the conveyor belt. Place the belt cleaner against the drive pulley with the center of the beam (3) at distance L from the center of the drive pulley, see picture 2.

How high to place the top of the scraper segments is determined by the gradient of the conveyor, the speed of the belt and the space available around the drive pulley. The belt cleaner is to be mounted just below the material flow when the conveyor is running. If the material flow hits the scraper's segments (1) the tear will shorten its lifespan dramatically. If that is the case, lower the belt cleaner slightly until the material flow passes the belt cleaner.

It is important that the carbide blade of the scraper segments (1) is fitted with a 90° angle to the drive pulley's surface, see picture 2.

- Assemble holder H (5), PU-bushing (6) and hose clamp (7) to the beam (3). Assemble the parts in the same order on both sides of the beam.
- Make two mounting brackets and weld these to the frame of belt conveyor where the holder H (5) should be fitted. The brackets shall each have two  $\varnothing 11$  mm holes, c-c 40mm and can be made from flat iron for example.
- Weld the mounting plates in the conveyor frame near the drive pulley, so that the holder H (3) can be assembled to the mounting bracket with distance (L) to the center of the drive pulley.
- Screw the holders H (5) to the mounting plates. Ensure that the L dimension is met and that the scraper blade in the scraper segment (1) is connecting to the conveyor belt in correct angle, (see picture 2).
- Center the belt cleaner sideways to the conveyor belt and lock the beam laterally with the hose clamps (7). Cut the beam (3) to the suitable length at both ends.
- Assemble the spring lever arm (9) to the lever arm fixing (8). Make sure that the end of the spring lever arm locks in the socket of the fixing (8).
- Insert the lever arm fixing (8) into the end of the beam (3). Drill a whole ( $\varnothing 7$  mm) right through the beam and **lock the lever arm fixing (8) using an M6 x 50 mm bolt (10)**.
- Weld the toothed washer to the conveyor frame. Tension the spring lever arm (9) and hook the snap hook onto the toothed washer. Find the optimal pressure by adjusting, see below.

Picture 2

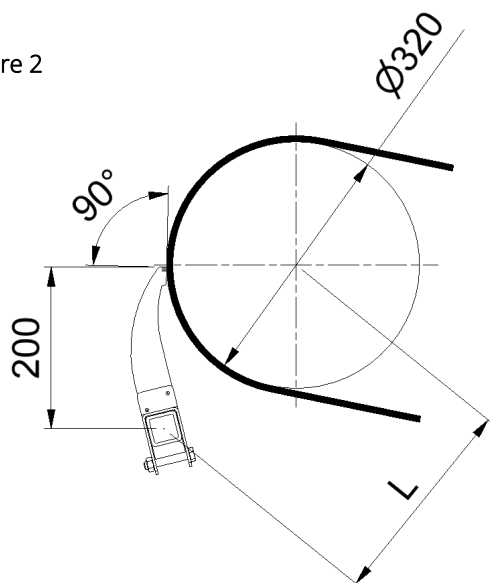

Drum pulley	L
Ø220	247mm
Ø270	264mm
Ø320	282mm
Ø400	313mm
Ø500	354mm
Ø630	410mm
Ø800	488mm

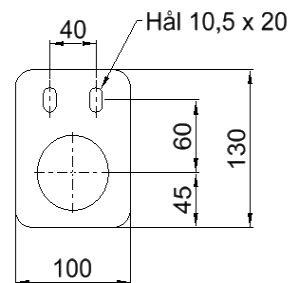

Note! Dont let the material flow hit the belt cleaner.

## ADJUSTMENTS

When all the parts are assembled according to the instructions above, turn the conveyor belt on to adjust the settings.

Find the optional pressure of the belt cleaner by eliminating noise, eliminating vibrations and watch how the cleaning performance changes when adjusting pressure of the pre-scraper.

In regular operation of the belt conveyor, vibrations and noise from the belt cleaner is a sign that adjustments is needed. Vibrations sometimes occur when the belt is running without material so keep the stand by-time to a minimum. Vibrations also occur when the belt has a sticky coating, for example of resin; keeping the belt clean is of essence. Vibrations can eventually cause fracture damages in the beam and must be eliminated. To reduce vibration and noise in other cases, follow the steps below. Remember to always turn off the belt conveyor before adjustments are made.

- Change the angle of the blades against the belt a few degrees
- Change the pressure of the belt cleaner against the belt.
- Make heavier, more sturdy mounting brackets for attaching to the conveyor frame.
- Increase the stability of the beam by fitting a small weight or a cantilever to the beam (3).

## MAINTENANCE

Inspect and clean the belt cleaner regularly, as a suggestion once a week. When 1 mm of the carbide blade on the scraper segment remains, change all the scraper segments (1).

When noise or vibration occurs, adjust the settings immediately.

### REPLACING THE SCRAPER BLADES

Change the scraper segments (1) by removing the snap hook from the toothed washer (9) and loosen the tension on the belt cleaner. The segments can be exchanged one by one or through removing the whole cassette (4 and 2) and slide the segments sideways out of the removable cassette (2). Snap the new scraper segments into place. When all the segments have been replaced and fastened, the spring lever arm can be tensioned again.

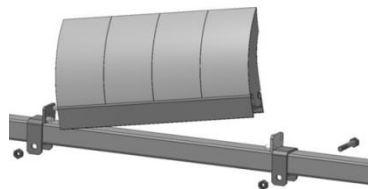
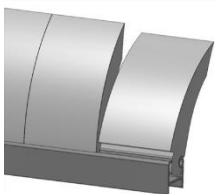

The scraper segment can be snapped in place (picture to the left) or the whole cassette can be removed so that the segments can be slid sideways out of the cassette (picture to the right).